



Technical Data

Qualification

MIL-PRF-6164F
API 16D on Nitrogen

Temperature Range

32F to 180F

Operating Mediums

Nitrogen
Seawater

Material Construction

Body 316 SS
Banjo N50
Rupture Plug N50
Rupture Disc 316 SS
ACV – See BOM

Materials Elastomers

Buna N
PTFE
UHMW

DCB Port Style

SAE-08 Dual
SAE-12
BSPP G-3/4

DCB Brand

Radoil
Hydac
Parker

Poseidon Deepwater Solutions

DCB SOLUTIONS

TRITON CHARGING VALVES are adapted to Depth Compensated Bottles (DCBs) using various adapters. Every brand of DCB is supported with both fuse blocks for the Nitrogen Side, as well as a port adapter for the Vacuum Side. The fuse block is universal between brand of DCB, with a dedicated “banjo bolt” to adapt to the charging port. Direct cross over with NOV part numbers on page 2.

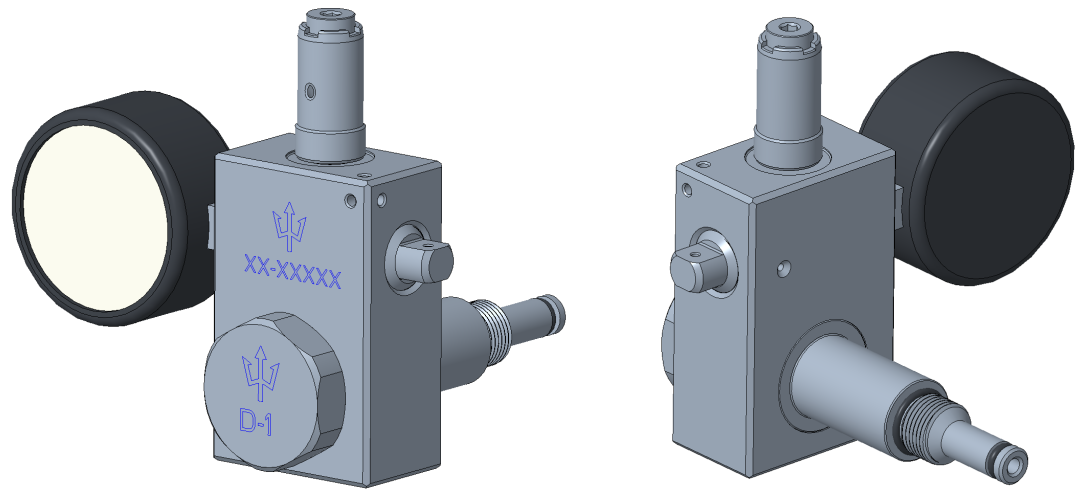

Nitrogen Fuse Block with Rupture Disc
(Radoil DCB Style 1 shown)

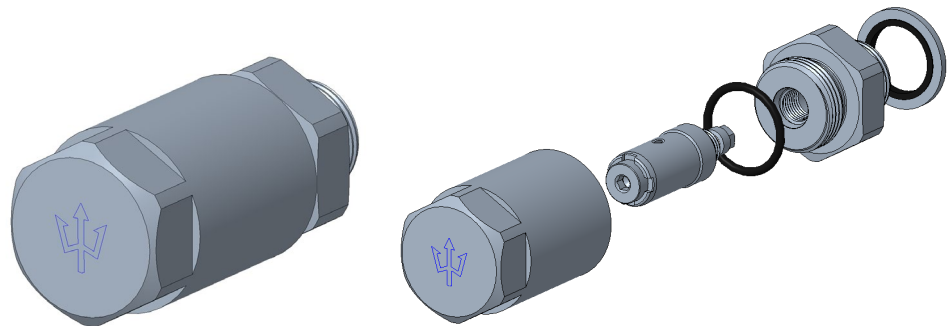

Vacuum Port adapter and Cap
(Hydac DCB Style 2 shown)

Warranty

12/18 for Materials,
Craftsmanship, and Defects.

*Full 3-year field warranty
for repairability*

www.poseidondeepwatersolutions.com

Sales@poseidonds.com



Poseidon Deepwater Solutions

NITROGEN PORT

Technical Data

Qualification

MIL-PRF-6164F

API 16D on Nitrogen

Temperature Range

32F to 180F

Operating Mediums

Nitrogen

Seawater

Material Construction

Body 316 SS

Banjo N50

Rupture Plug N50

Rupture Disc 316 SS

ACV – See BOM

Materials Elastomers

Buna N

PTFE

UHMW

DCB Port Style

SAE-08 Dual

SAE-12

BSPP G-3/4

DCB Brand

Radoil

Hydac

Parker

Poseidon Deepwater Solutions offers improved fuse blocks for the DCB. The banjo seal damage and block interference have been addressed. Additionally, the rupture disc is repairable without removal of the block which can introduce damage on the critical seals. The block has been designed to be universal between all brands of DCB without interference on the end manifolds. This enables a mixed fleet to be supported with only dedicated banjo bolts. Refer to the chart below to identify what assembly is needed based on the brand of DCB. Fuse block assembly comes complete with all seals and charging valve ready to use.

DCB	Port	Style	Nitrogen Port	
			NOV	PDS
Radoil	SAE-8 ORB dual	1	16578587-001	006-N1
Hydac	BSPP G3/4	2	16579101-001	006-N2
Parker	SAE-12 ORB	3	16578886-001	006-N3

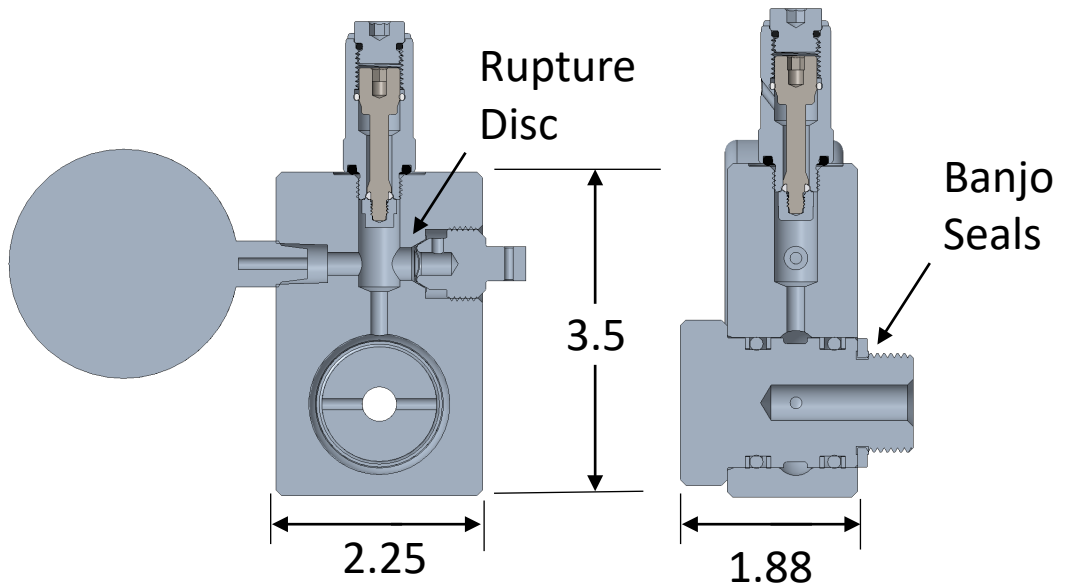

SPARE PARTS

DCB	Nitrogen Port				
	Repair Kit*	Banjo Seal Kit	Banjo Bolt	Gage	Rupture Disc*
Radoil	006-N1-RK	006-N1-SK	006-0368	006-0367	006-0365
Hydac	006-N2-RK	006-N2-SK	006-0139		
Parker	006-N3-RK	006-N3-SK	006-0389		

*Repair Kit contains a rupture disc and a Banjo seal kit

www.poseidondeepwatersolutions.com

Sales@poseidonds.com

Office 281-725-0030

R001

Warranty
12/18 for Materials,
Craftsmanship, and Defects.
Full 3-year field warranty
for repairability



Poseidon Deepwater Solutions

VACUUM PORT

Technical Data

Qualification

MIL-PRF-6164F

API 16D on Nitrogen

Temperature Range

32F to 180F

Operating Mediums

Nitrogen

Seawater

Material Construction

Body 316 SS

Banjo N50

Rupture Plug N50

Rupture Disc 316 SS

ACV – See BOM

Materials Elastomers

Buna N

PTFE

UHMW

DCB Port Style

SAE-08 Dual

SAE-12

BSPP G-3/4

DCB Brand

Radoil

Hydac

Parker

TRITON Charging Valves can be used on the DCB Vacuum Port. An adapter is used to convert from the DCB port to a ½-20 UNF / SAE-05 connection. A depth rated cap provides a secondary barrier against seawater intrusion and protects the valve. The cap is universal between all DCB brands. A dedicated adapter is used for each DCB, be sure to check the port style chart. Each port adapter kit comes complete with all seals, cap, and a valve ready to use.

The Port Adapter and Charging Valve can be used in the Nitrogen Side but will not provide over-pressure protection.

PORT ADAPTER

DCB	Port	Style	Vacuum
Radoil	SAE-8 ORB dual	1	006-V1
Hydac	BSPP G3/4	2	006-V2
Parker	SAE-12 ORB	3	006-V3

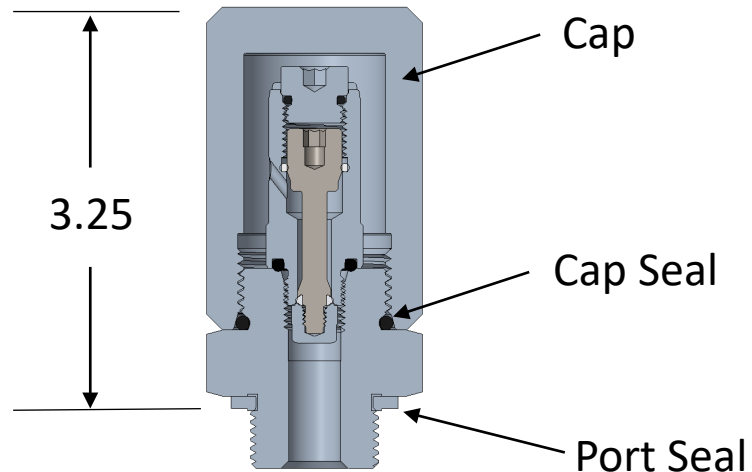

SPARE PARTS

DCB	Vacuum			
	Seal Kit	Port Seal	Cap Seal	Cap
Radoil	006-V1-RK	006-0371	006-0225	006-0224
		006-0383		
Hydac	006-V2-RK	006-0145	006-0225	006-0224
Parker	006-V3-RK	006-0238	006-0225	006-0224

*Seal Kit contains Port Seals and Cap Seal

Warranty
12/18 for Materials, Craftsmanship, and Defects.
Full 3-year field warranty for repairability

www.poseidondeepwatersolutions.com

Sales@poseidonds.com

Office 281-725-0030

1422 Vanderwilt Ln Ste A - Katy, TX - 77449

R001